



A Division of Major Industries, Inc.

AUBURN® SKYLIGHTS

P.O. Box 306
 Wausau, Wisconsin 54402-0306
 Phone: (715) 842-4616
 Fax: (715) 848-3336
 Toll Free: (888) SkyCost (888-759-2678)
<http://www.majorskylights.com>
 e-mail: info@majorskylights.com

SILLS & FRAMES

*ITALIC DIMENSIONS
 REPRESENT STRAIGHT
 ON VIEW FOR
 DRAWING ELEVATIONS*

SCALE: 1/2" = 1"

(A)

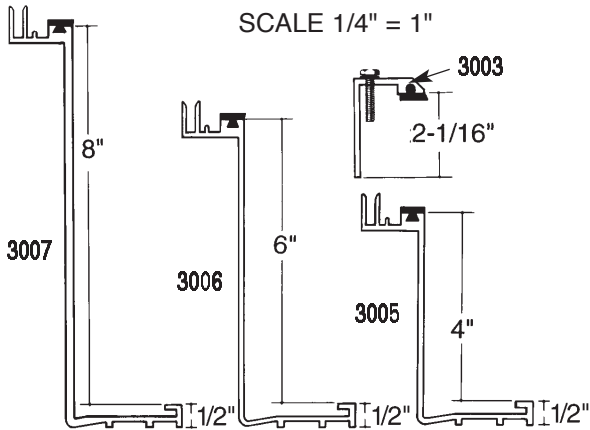
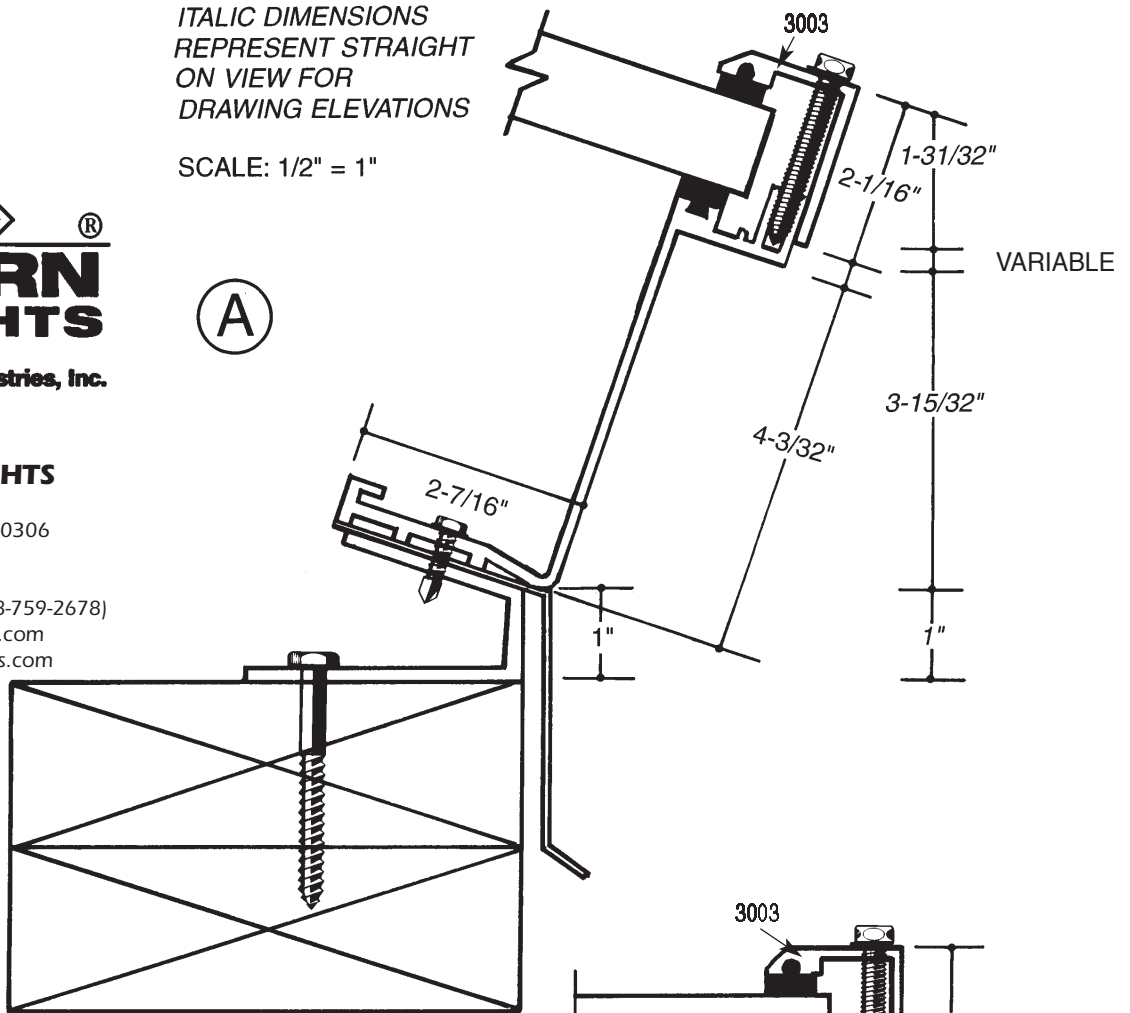

SCALE 1/4" = 1"

(B)

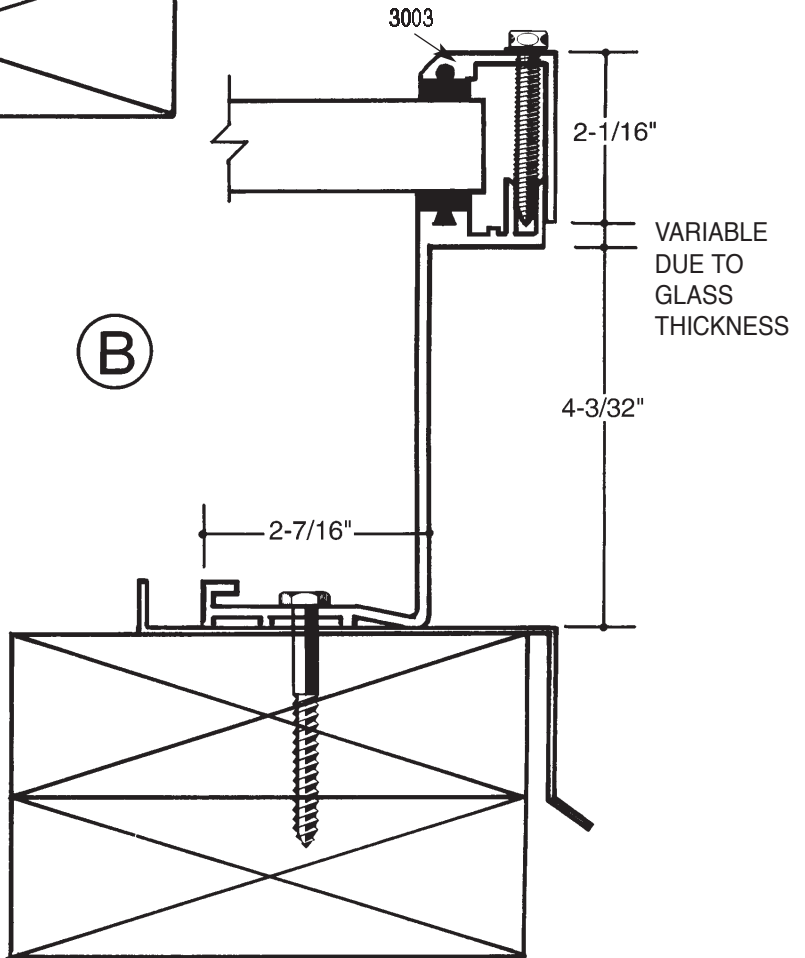

TERMS OF USE:

This technical manual is designed to allow an architect or specifier to use Major's daylighting system in their projects. Thus, you may extract drawings, specifications, and details for use in your projects, and you may distribute these materials as necessary in association with the project. However, Major Industries still retains exclusive copyright to their materials; we only grant rights to use the materials in association with projects or project proposals. Any other use, including distribution, modification, storage, or dissemination to third parties unrelated to the project is strictly prohibited.



A Division of Major Industries, Inc.

AUBURN® SKYLIGHTS

P.O. Box 306
 Wausau, Wisconsin 54402-0306
 Phone: (715) 842-4616
 Fax: (715) 848-3336
 Toll Free: (888) SkyCost (888-759-2678)
<http://www.majorskylights.com>
 e-mail: info@majorskylights.com

**PERIMETER
 FRAME**

Ⓒ
 SILL

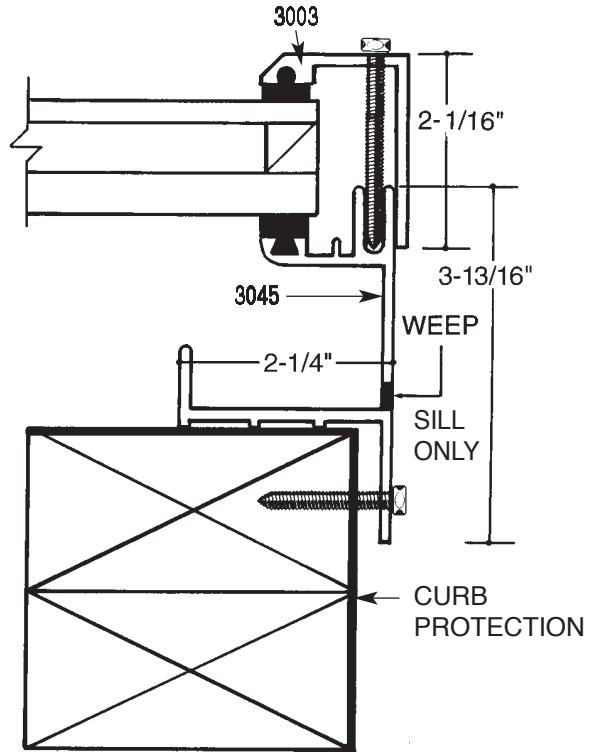

HEAD
 Ⓓ
 Ⓔ
 JAMB

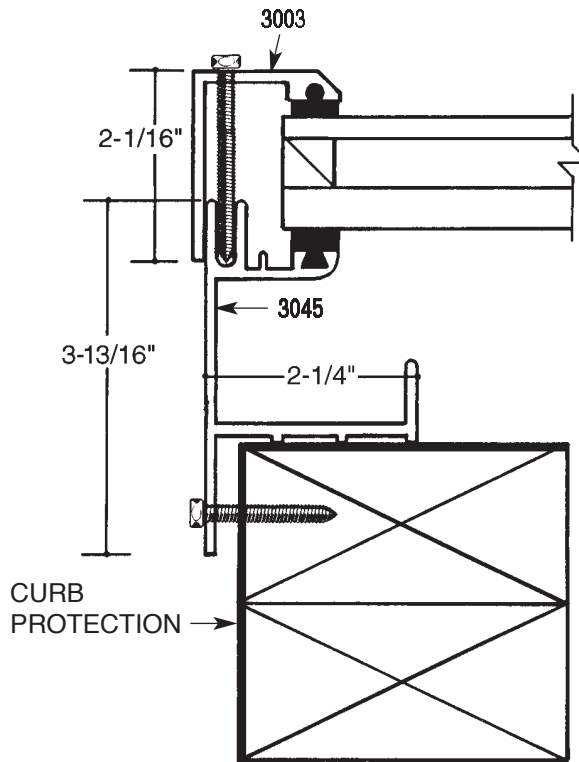



A Division of Major Industries, Inc.

AUBURN® SKYLIGHTS

P.O. Box 306
Wausau, Wisconsin 54402-0306
Phone: (715) 842-4616
Fax: (715) 848-3336
Toll Free: (888) SkyCost (888-759-2678)
<http://www.majorskylights.com>
e-mail: info@majorskylights.com

SILLS

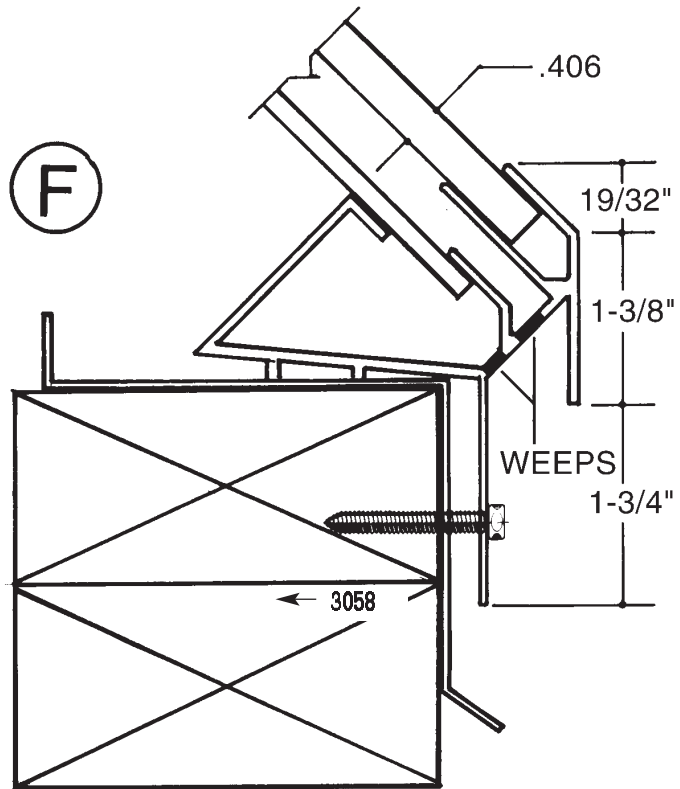



A Division of Major Industries, Inc.

AUBURN® SKYLIGHTS

P.O. Box 306
 Wausau, Wisconsin 54402-0306
 Phone: (715) 842-4616
 Fax: (715) 848-3336
 Toll Free: (888) SkyCost (888-759-2678)
<http://www.majorskylights.com>
 e-mail: info@majorskylights.com

**HIP/RIDGE
 COVERS**

RAFTERS

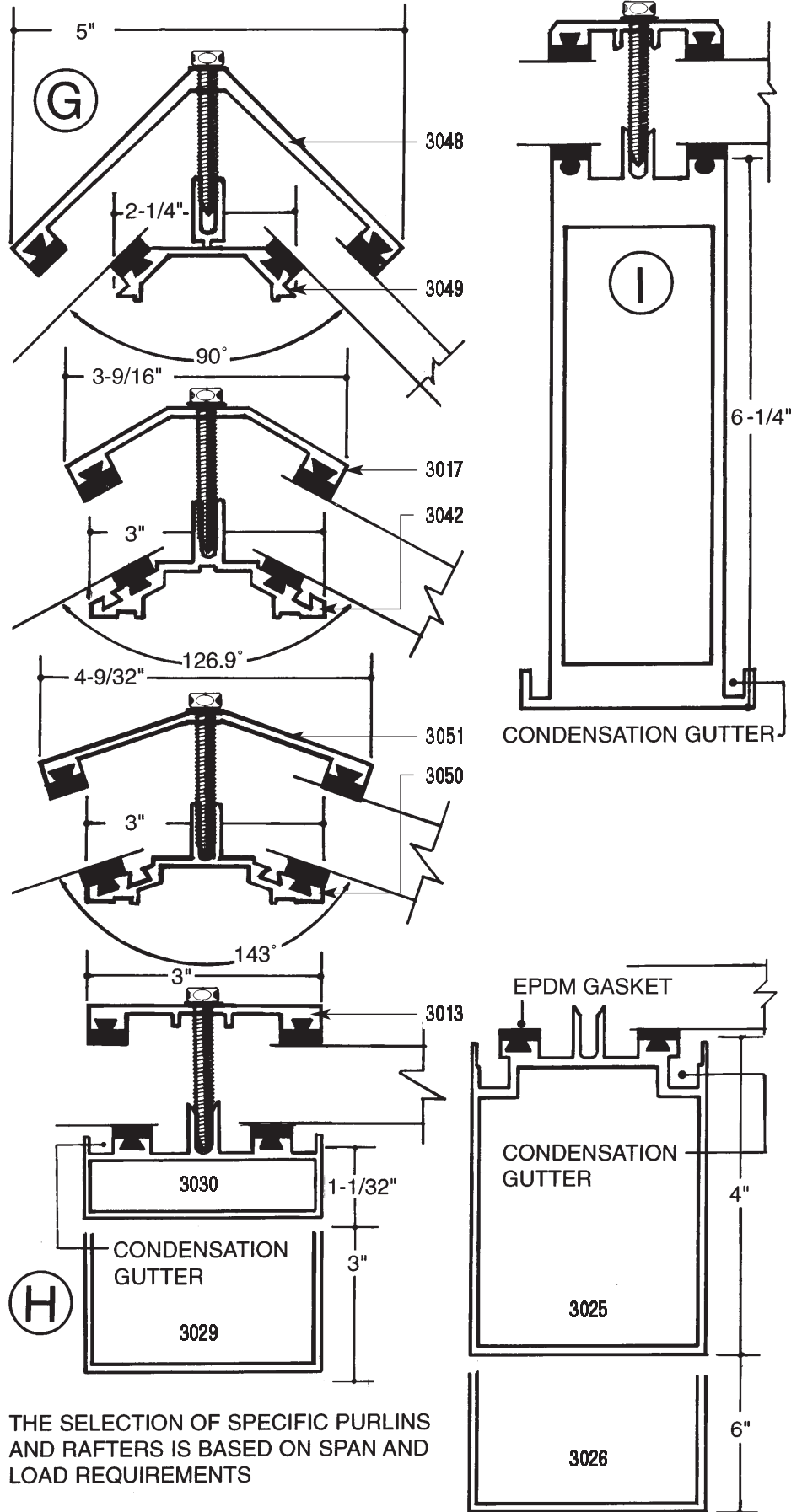

THE SELECTION OF SPECIFIC PURLINS AND RAFTERS IS BASED ON SPAN AND LOAD REQUIREMENTS

SCALE: 1/2" = 1"



A Division of Major Industries, Inc.

AUBURN® SKYLIGHTS

P.O. Box 306
 Wausau, Wisconsin 54402-0306
 Phone: (715) 842-4616
 Fax: (715) 848-3336
 Toll Free: (888) SkyCost (888-759-2678)
<http://www.majorskylights.com>
 e-mail: info@majorskylights.com

DETAIL

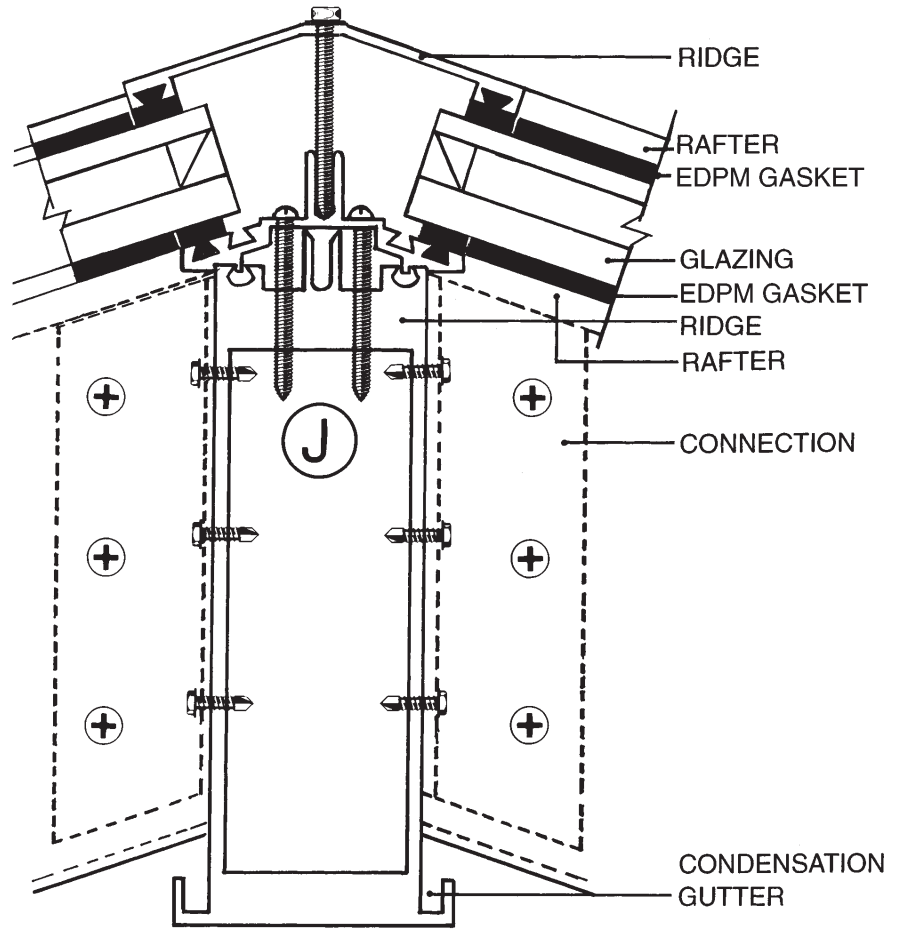

**SKYLIGHT
 ENDWALL**

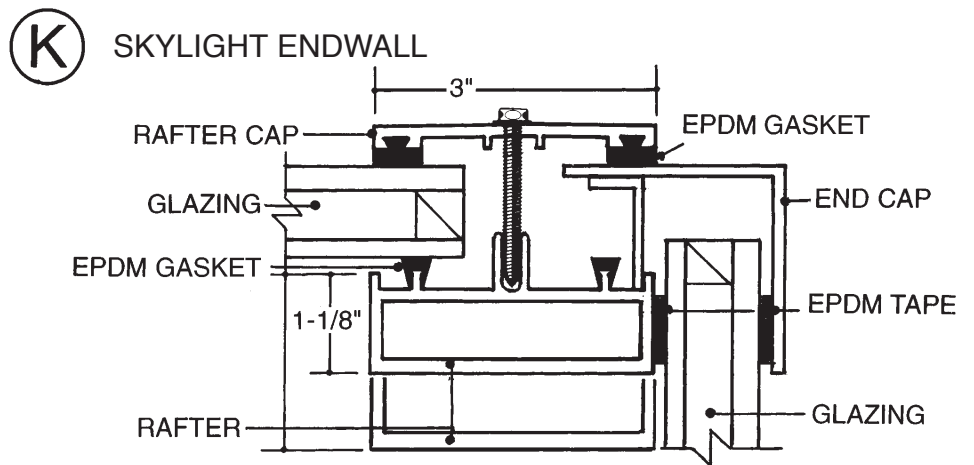

SCALE 1/2" = 1"



A Division of Major Industries, Inc.

AUBURN® SKYLIGHTS

P.O. Box 306
 Wausau, Wisconsin 54402-0306
 Phone: (715) 842-4616
 Fax: (715) 848-3336
 Toll Free: (888) SkyCost (888-759-2678)
<http://www.majorskylights.com>
 e-mail: info@majorskylights.com

**SKYLIGHT
 DETAILS**

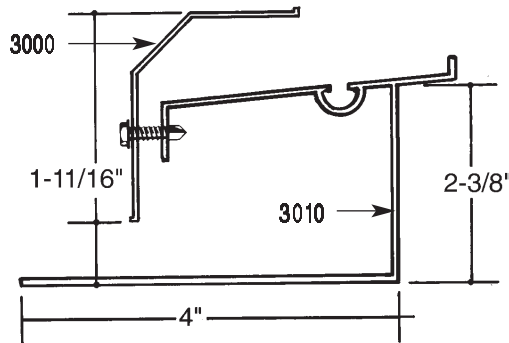
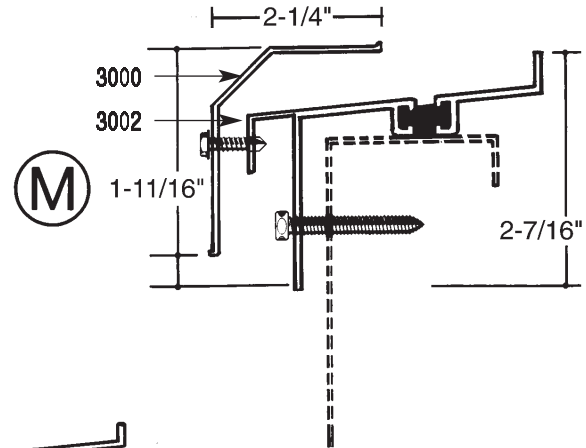
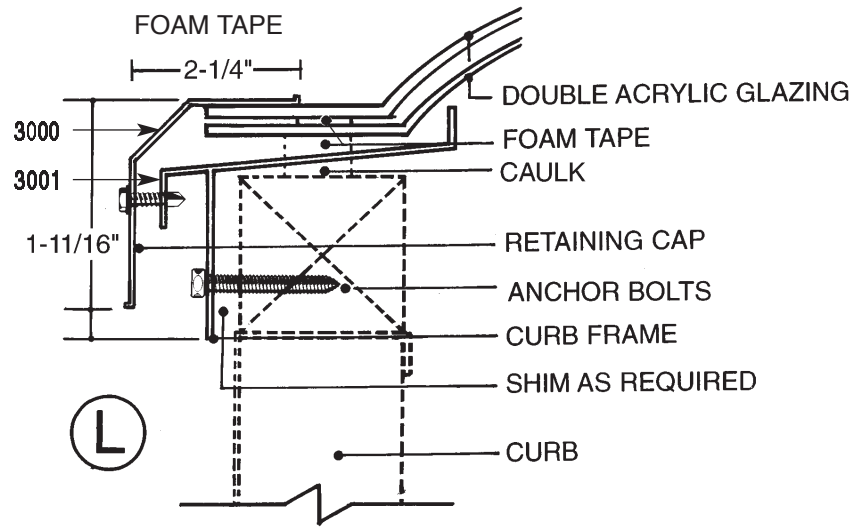

(N)

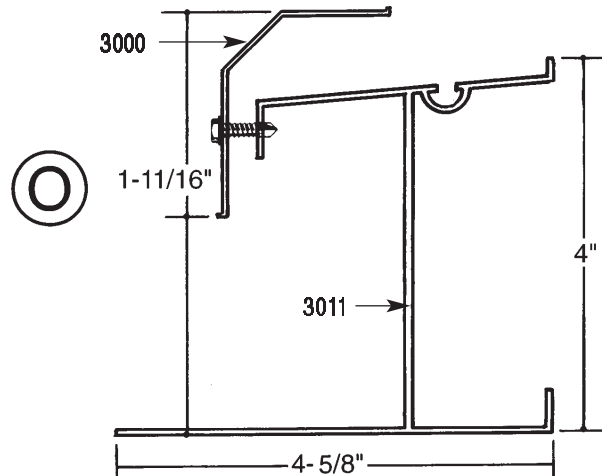

(O)

SCALE 1/2" = 1"



A Division of Major Industries, Inc.

AUBURN® SKYLIGHTS

P.O. Box 306
Wausau, Wisconsin 54402-0306
Phone: (715) 842-4616
Fax: (715) 848-3336
Toll Free: (888) SkyCost (888-759-2678)
<http://www.majorskylights.com>
e-mail: info@majorskylights.com

**ASSEMBLY
DETAILS**

